

DUNO PRO

Stropní LED svítidlo



[V] 220-240 AC	[Hz] 50	[°] 120	≥15000	(h) 20000	Ellipse ≤ 6x Mackdam	Ra 80
Hg	SMD			IP 54		[°C] -20÷40
		[mm²] 0,5÷1,5	0,5m			



DUNO PRO 15W-NW-O



	[W]	[lm]	Tc [K]	
DUNO PRO 15W-NW-O 31240	15	1500	4000	bílá
DUNO PRO 24W-NW-O 31241	24	2400	4000	bílá

- Materiál korpusu: plast
- Materiál difuzoru: plast



DUNO PRO 15W-NW-O



DUNO PRO 24W-NW-O

DUNO PRO

Stropní LED svítidlo

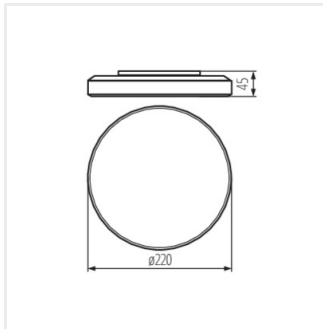

DUNO PRO 15W-NW-O

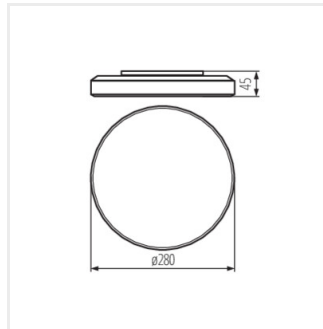

DUNO PRO 24W-NW-O